

Math 213 - Double Integrals

Peter A. Perry

University of Kentucky

October 11, 2019

Reminders

- Homework B6 on 14.7 (closed set method) is due tonight
- Homework B7 on 14.8 (Lagrange multipliers) is due Monday!
- There is a drop-in review session for Exam II on Monday, October 14, 6:00-8:00 PM in KAS 213
- Exam II takes place on Wednesday, October 16, 5:00-7:00 PM

Unit II: Functions of Several Variables

13.3-4 Lecture 11: Velocity and Acceleration

14.1 Lecture 12: Functions of Several Variables

14.3 Lecture 13: Partial Derivatives

14.4 Lecture 14: Linear Approximation

14.5 Lecture 15: Chain Rule, Implicit Differentiation

14.6 Lecture 16: Directional Derivatives and the Gradient

14.7 Lecture 17: Maximum and Minimum Values, I

14.7 Lecture 18: Maximum and Minimum Values, II

14.8 Lecture 19: Lagrange Multipliers

15.1 **Double Integrals**

15.2 Double Integrals over General Regions

Exam II Review

Learning Goals

- Understand why the volume under a surface can be computed as a double integral, a limit of double Riemann sums
- Understand how to compute double integrals over rectangles as *iterated integrals*
- Understand how to find the *average value* of a function of two variables over a rectangular domain

Calculus I: Areas under Curves

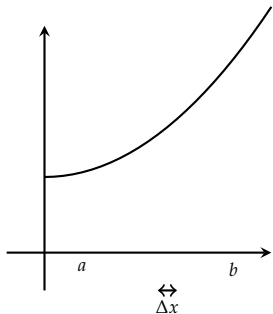

The area under the graph of $y = f(x)$ between $x = a$ and $x = b$ is approximated by *Riemann sums*

$$\sum_{i=1}^n f(x_i^*) \Delta x$$

where

$$\Delta x = \frac{b - a}{n}$$

$$x_i = a + i\Delta x$$

$$x_i^* \in [x_{i-1}, x_i]$$

A Riemann sum with $n = 8$ for $\int_a^b f(x) dx$

Calculus I: Areas under Curves

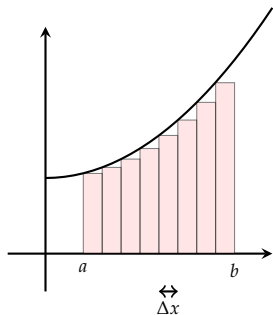

A Riemann sum with $n = 8$ for $\int_a^b f(x) dx$

The area under the graph of $y = f(x)$ between $x = a$ and $x = b$ is approximated by *Riemann sums*

$$\sum_{i=1}^n f(x_i^*) \Delta x$$

where

$$\Delta x = \frac{b-a}{n}$$

$$x_i = a + i\Delta x$$

$$x_i^* \in [x_{i-1}, x_i]$$

$$x_i^* = x_{i-1} \quad (\text{left endpoint})$$

Calculus I: Areas under Curves

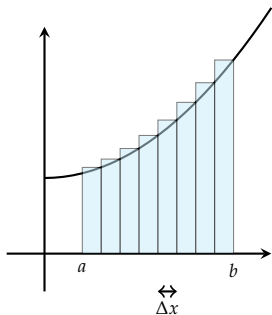

A Riemann sum with $n = 8$ for $\int_a^b f(x) dx$

The area under the graph of $y = f(x)$ between $x = a$ and $x = b$ is approximated by *Riemann sums*

$$\sum_{i=1}^n f(x_i^*) \Delta x$$

where

$$\Delta x = \frac{b - a}{n}$$

$$x_i = a + i\Delta x$$

$$x_i^* \in [x_{i-1}, x_i]$$

$$x_i^* = x_{i-1} \quad \text{(left endpoint)}$$

$$x_i^* = x_i \quad \text{(right endpoint)}$$

Calculus I: Areas under Curves

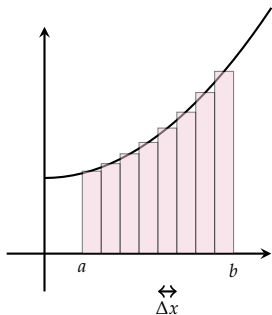

A Riemann sum with $n = 8$ for $\int_a^b f(x) dx$

The area under the graph of $y = f(x)$ between $x = a$ and $x = b$ is approximated by *Riemann sums*

$$\sum_{i=1}^n f(x_i^*) \Delta x$$

where

$$\Delta x = \frac{b - a}{n}$$

$$x_i = a + i\Delta x$$

$$x_i^* \in [x_{i-1}, x_i]$$

$$x_i^* = x_{i-1} \quad (\text{left endpoint})$$

$$x_i^* = x_i \quad (\text{right endpoint})$$

$$x_i^* = \frac{x_{i-1} + x_i}{2} \quad (\text{midpoint})$$

Calculus I: Areas under Curves

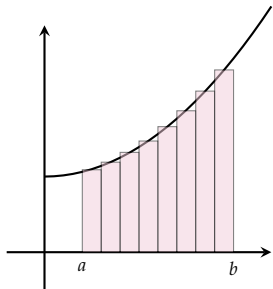

The exact area under the graph of $f(x)$ between $x = a$ and $x = b$ is

$$\int_a^b f(x) dx$$

The Fundamental Theorem of Calculus states that, if f is continuous on $[a, b]$, then

$$\int_a^b f(x) dx = F(b) - F(a)$$

for any antiderivative F of f .

We extended these ideas to compute the *net area* under the graph of a signed function and the *average value* of a function f over an interval $[a, b]$

Calculus II: Volumes under Surfaces

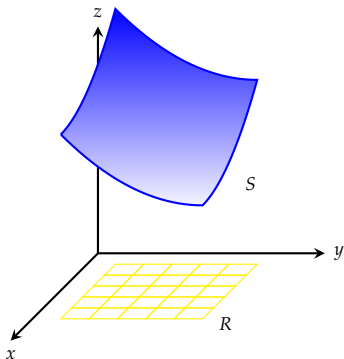

Problem Find the volume between the rectangle

$$R = [a, b] \times [c, d]$$

in the xy plane and the surface

$$S = \{(x, y, z) : (x, y) \in R, z = f(x, y)\}$$

if f is a continuous function.

- 1 Divide the rectangle R into an $n \times n$ 'grid' of subrectangles $R_{i,j}$
- 2 For each subrectangle $R_{i,j}$, make a box of height $f(x_i^*, y_j^*)$
- 3 Add up the volumes of the n^2 boxes

Volumes Under Surfaces

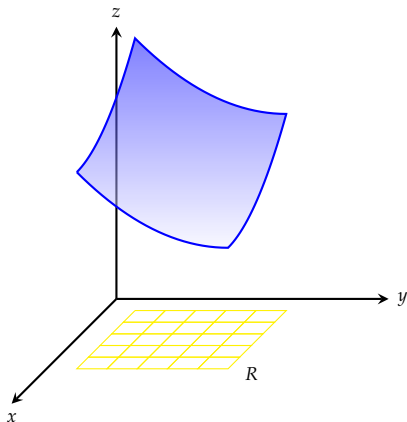

Volumes Under Surfaces

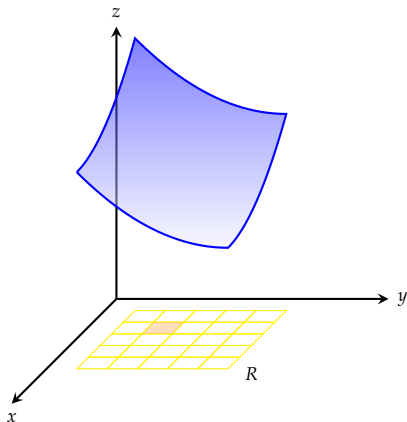

- Pick a rectangle $R_{i,j}$ in the grid, area ΔA

Volumes Under Surfaces

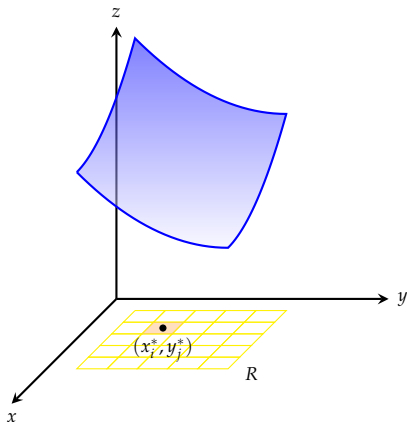

- Pick a rectangle $R_{i,j}$ in the grid, area ΔA
- Pick (x_i^*, y_j^*) in the rectangle

Volumes Under Surfaces

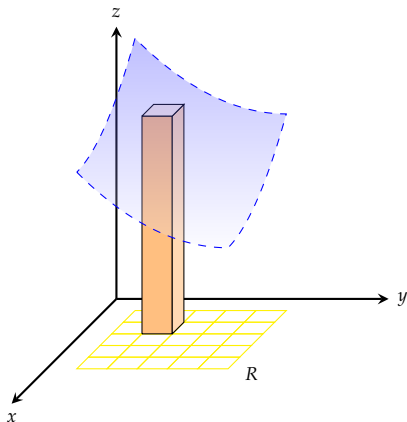

- Pick a rectangle $R_{i,j}$ in the grid, area ΔA
- Pick (x_i^*, y_j^*) in the rectangle
- Make a box of height $f(x_i^*, y_j^*)$ over $R_{i,j}$

Volumes Under Surfaces

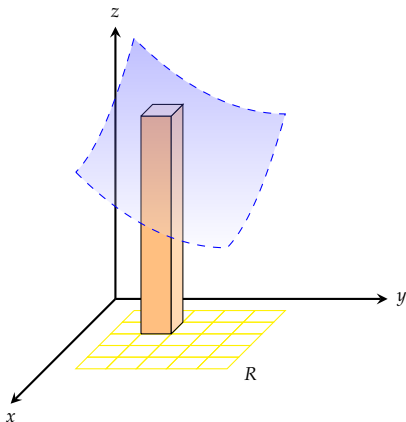

- Pick a rectangle R_{ij} in the grid, area ΔA
- Pick (x_i^*, y_j^*) in the rectangle
- Make a box of height $f(x_i^*, y_j^*)$ over R_{ij}
- The volume of the box is $V_{ij} = f(x_i^*, y_j^*) \Delta A$

Volumes Under Surfaces

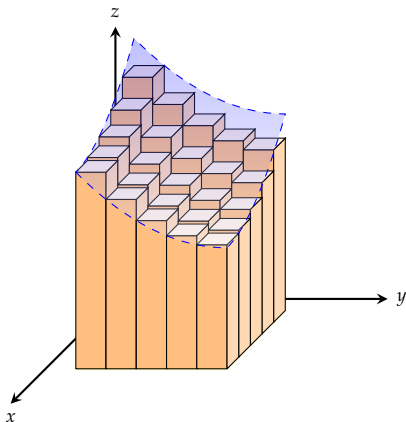

- Pick a rectangle $R_{i,j}$ in the grid, area ΔA
- Pick (x_i^*, y_j^*) in the rectangle
- Make a box of height $f(x_i^*, y_j^*)$ over $R_{i,j}$
- The volume of the box is $V_{ij} = f(x_i^*, y_j^*) \Delta A$
- The approximate volume under the surface is

$$\sum_{i=1}^n \sum_{j=1}^n f(x_i^*, y_j^*) \Delta A$$

Volumes Under Surfaces

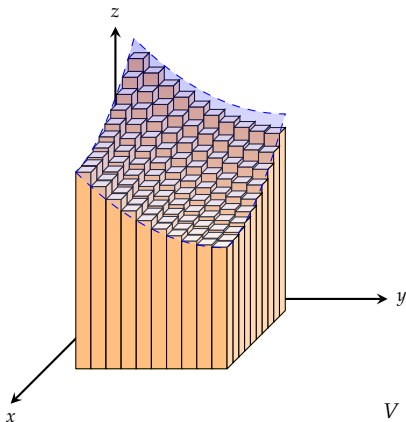

- Pick a rectangle $R_{i,j}$ in the grid, area ΔA
- Pick (x_i^*, y_j^*) in the rectangle
- Make a box of height $f(x_i^*, y_j^*)$ over $R_{i,j}$
- The volume of the box is $V_{ij} = f(x_i^*, y_j^*) \Delta A$
- The approximate volume under the surface is

$$\sum_{i=1}^n \sum_{j=1}^n f(x_i^*, y_j^*) \Delta A$$

$$V = \lim_{n \rightarrow \infty} \sum_{i,j=1}^n f(x_i^*, y_j^*) \Delta A$$

Volumes By Integration

If $R = [a, b] \times [c, d]$ and

$$S = \{(x, y, z) : z = f(x, y), (x, y) \in R\}$$

then the volume between R and S is

$$V = \lim_{n \rightarrow \infty} \sum_{i,j=1}^n f(x_i^*, y_j^*) \Delta A = \iint_R f(x, y) dA$$

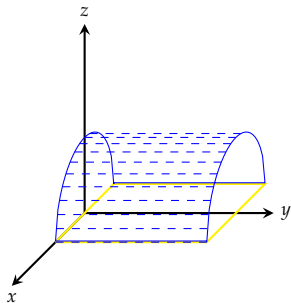

Find $\iint_R f(x, y) dA$ if

$$R = [-1, 1] \times [0, 2]$$

and

$$f(x, y) = \sqrt{1 - x^2}$$

Can you do this without calculus?

Iterated Integrals

When you studied one-variable calculus, you first found out how to compute antiderivatives and then you learned how to compute definite integrals using them

Now that you're studying two variable calculus, you'll first learn about *iterated integrals* and then learn how to compute integrals over rectangles with them.

Suppose R is a rectangle $[a, b] \times [c, d]$ and f is a continuous function on R . Then

$$A(x) = \int_c^d f(x, y) dy$$

is a function of x . For example if $f(x, y) = x^2y$ and $R = [1, 2] \times [3, 4]$, then

$$\int_3^4 (x^2y) dy = \left. \frac{x^2y^2}{2} \right|_3^4 = \frac{7}{2}x^2$$

We then compute $\int_a^b A(x) dx$. For example

$$\int_1^2 \frac{7}{2}x^2 dx = \left. \frac{7}{6}x^3 \right|_{x=1}^{x=2} = \frac{49}{6}$$

Iterated Integrals

If $f(x, y)$ is a continuous function on a rectangle $R = [a, b] \times [c, d]$, the **iterated integral** of f is

$$\int_a^b \int_c^d f(x, y) \, dy \, dx = \int_a^b \left(\int_c^d f(x, y) \, dy \right) dx$$

-
- 1 Find $\int_1^4 \int_0^2 (6x^2y - 2x) \, dy \, dx$
 - 2 Find $\int_1^3 \int_1^5 \frac{\ln y}{xy} \, dy \, dx$
 - 3 (Ringer) $\int_0^1 \int_1^2 (x + e^{-y}) \, dx \, dy$

Fubini's Theorem

Theorem If f is continuous on the rectangle

$$R = \{(x, y) : a \leq x \leq b, c \leq y \leq d\}$$

then

$$\iint_R f(x, y) dA = \int_a^b \int_c^d f(x, y) dy dx = \int_c^d \int_a^b f(x, y) dx dy.$$

Evaluate these double integrals.

- ① $\iint_R x \sec^2 y dA, R = [0, 2] \times [0, \pi/4]$
- ② $\iint_R \frac{xy^2}{x^2 + 1} dA, R = [0, 1] \times [-3, 3]$
- ③ $\iint_R \frac{1}{1 + x + y} dA, R = [1, 3] \times [1, 2]$

Volumes by Iterated Integrals

- ① Find the volume of the solid that lies under the plane

$$4x + 6y - 12z + 15 = 0$$

and above the rectangle $[-1, 2] \times [-1, 1]$

- ② Find the volume of the solid lying under the elliptic paraboloid

$$x^2/4 + y^2/9 + z = 1$$

and above the rectangle $[-1, 1] \times [-2, 2]$

Preview: Integrals over General Regions

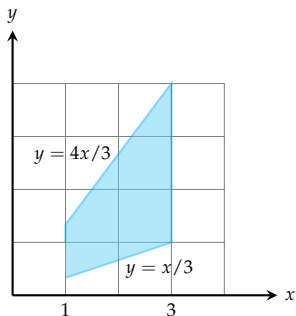

Find

$$\iint_D (x + 3y) \, dA$$

if

$$D = \{1 \leq x \leq 3, x/3 \leq y \leq 4x/3\}$$

Preview: Integrals over General Regions

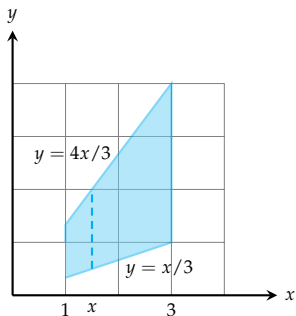

Find

$$\iint_D (x + 3y) \, dA$$

if

$$D = \{1 \leq x \leq 3, \ x/3 \leq y \leq 4x/3\}$$

$$\iint_D (x + 3y) \, dA =$$

$$\int_1^3 \left(\int_{x/3}^{4x/3} (x + 3y) \, dy \right) dx$$

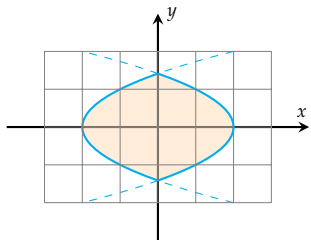

Find

$$\iint_D 1 \, dA$$

if D is the region enclosed by the curves

$$x = 2 - y^2$$

and

$$x = -2 + y^2.$$

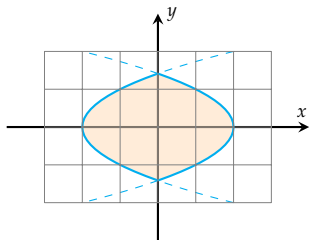

Find

$$\iint_D 1 \, dA$$

if D is the region enclosed by the curves

$$x = 2 - y^2$$

and

$$x = -2 + y^2.$$

$$D = \{-\sqrt{2} \leq y \leq \sqrt{2}, -2 + y^2 \leq x \leq 2 + y^2\}$$

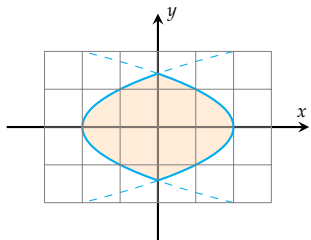

Find

$$\iint_D 1 \, dA$$

if D is the region enclosed by the curves

$$x = 2 - y^2$$

and

$$x = -2 + y^2.$$

$$D = \{-\sqrt{2} \leq y \leq \sqrt{2}, -2 + y^2 \leq x \leq 2 + y^2\}$$

$$\iint_D 1 \, dA = \int_{-\sqrt{2}}^{\sqrt{2}} \left(\int_{-2+y^2}^{2-y^2} 1 \, dx \right) dy$$

Average Values

The average value of $y = f(x)$ on $[a, b]$ is

$$f_{\text{av}} = \frac{1}{b-a} \int_a^b f(x) dx$$

The average value of $z = f(x, y)$ on a rectangle R with area $A(R)$ is

$$f_{\text{av}} = \frac{1}{A(R)} \iint_R f(x, y) dA$$

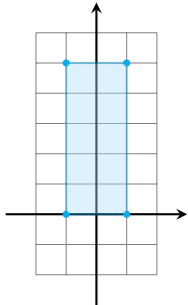

Find the average value of $f(x, y) = x^2y$ over a rectangle with vertices $(-1, 0)$, $(-1, 5)$, $(1, 5)$, and $(1, 0)$.